

ELECTRICAL OPERATED DIRECTIONAL CONTROL VALVE



Technical Specification

Specification		6	10		
Working pressure (Bar)	Oil P,A,B	350	315		
	Oil ports T	100	100		
Max. Flow (L/min)		80	120		
Working fluid		Mineral oil; phosphate-ester			
Fluid temp. (°C)		-20~70			
Viscosity (mm ² /s)		2.8~100			
Working voltage	DC	12	24		
	AC	110/50Hz	220/50Hz		
Max. Switch frequency (T/h)		1500 (DC)	7200 (AC)		
Insulation grade		IP65			
Weight (kg)	Single solenoid	1.45(DC)	1.4(AC)	5.1(DC)	4.3(AC)
	Double solenoid	1.95(DC)	1.9(AC)	6.7(DC)	5.1(AC)
Cleanliness	The maximum allowable cleanliness of the oil should be according to 9th degree of Standard NAS 1638. It is suggested that the minimum filter rating should be $\beta_{10} \geq 75$.				

Model description

WHV - 6 - * / 60 - * - * - * - * - * - *

Nominal Size : 6 = 06

10 = 10

Symbol

Series Number 60

Working Voltage

D12	DC 12V
D24	DC 24V
A110	AC 110V
A220	AC 220V
B110	AC 110V Rectified
B220	AC 220V Rectified

No Code Square Connector with Light
Z6 Wire box type

Remarks

No Code NBR Seals
v FPM Seals

No Code without hand emergency

08	Ø0,8	Damping
10	Ø1,0	Damping
12	Ø1,2	Damping

No Code without hand emergency
N 9 with concealed hand emergency

ELECTRICAL OPERATED DIRECTIONAL CONTROL VALVE

Code Symbol

Spring return

302		2828		2828L		282	
303		2838		2838L		283	
304		2848		2848L		288	
305		2858		2858L		282L	
306		2868		2868L		283L	
307		2878		2878L		288L	
309		2898		2898L		With detent	
3010		28108		28108L			2D2
3011		28118		28118L			2D3
3012		28128		28128L			2D8
3025		28258		28258L		No spring return and no detent mechanical positioning	
3029		28298		28298L			2N2
							2N3
							2N8

Note: *D* (No spring return mechanical positioning) solenoid directional control valve should be installed horizontally.

ELECTRICAL OPERATED DIRECTIONAL CONTROL VALVE

Name Of Solenoid

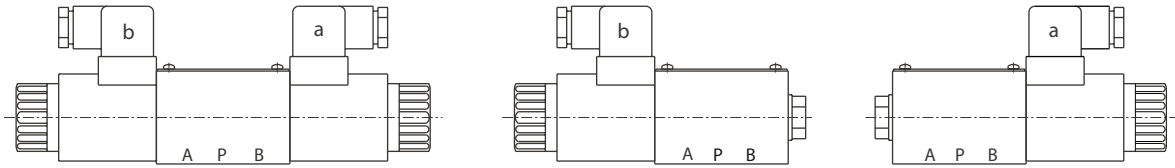

1. a When movement a, P→A B→T
2. b When movement b, P→B A→T
3. Oil flow in the opposite direction with the above - mentioned movement for 305,306 symbol Valve.

6 Specification Performance Curve (Measured at $v=41\text{mm}^2/\text{s}$ and $t=50^\circ\text{C}$)

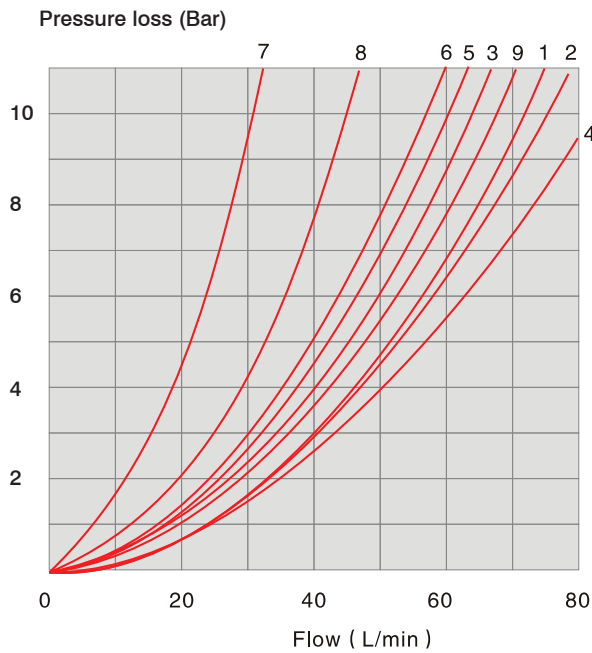

Function code	Direction			
	P→A	P→B	A→T	B→T
288 288L	3	3	-	-
283	1	1	3	1
282 282L	5	5	3	3
302	3	3	1	1
305	1	3	1	1
305	6	6	9	9
303	2	4	2	2
304	1	1	2	1
3010,1012	3	3	4	9
309	2	3	3	3
3025	3	1	1	1
3029	5	5	4	-
307	1	2	1	1

7. Spool type "3029" located in the control position A →B
 8. Spool symbol 306 in the neutral position P →T

ELECTRICAL OPERATED DIRECTIONAL CONTROL VALVE

6 Specification Working Limits (The working limits for directional valves have determined by using solenoids at their operating temperature, 10% under voltage and with no pre-loading of the tank)

With regard to the four-way valve, the normal flow data as shown is get from the regular use of two directions of the flow (e.g. P to A, and simultaneous return flow from B to T). See tables. If only one flow direction is needed, for example: When a four port valve which is closed up port A or port B, used as a three-way valve, the Maximum flow may be very small in the serious condition.

DC solenoid operation				AC solenoid operation			
DC D24, D1 2, B220, B110				AC A110, A220, 50HZ			
Curve	Symbol			Curve	Symbol		
1	288	288L1		11	288	288L1	
2	307			12	307		
3	288	288L		13	288	288L	
4	305	3025		14	305	3025	
5	304			15	306		
6	306	303		16	303		
7	2N8	2D8	3010 301	17	2N8	2D8	2N3 2D3
8	283	282	282L		2N2	2D2	302 304 3010
9	309				309	3029	3012
10	302	3029	2N3	18	283	282	282L
	2D3	2N2	2D2				

Working pressure (Bar)

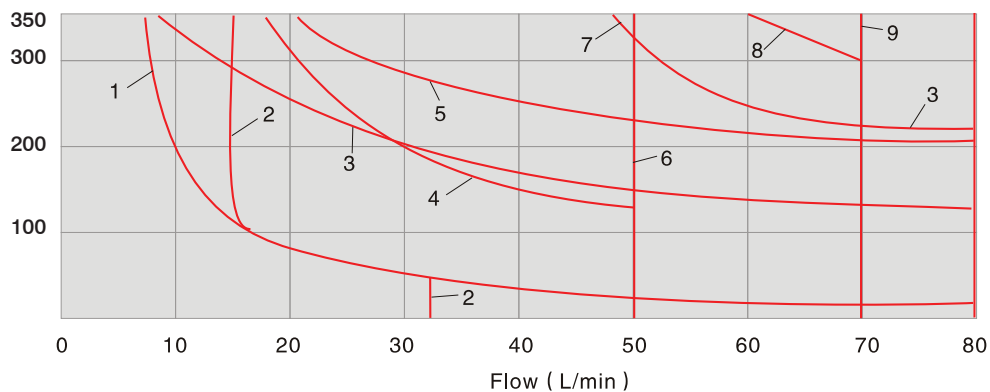

- 1) No manual emergency operation
- 2) Oil return from actuator to oil tank

Working pressure (Bar)

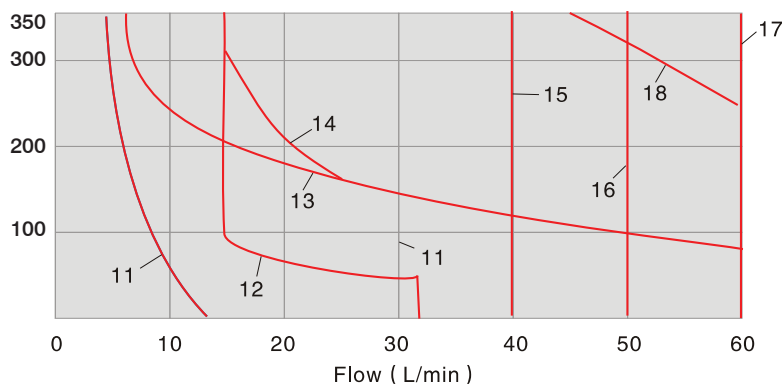

ELECTRICAL OPERATED DIRECTIONAL CONTROL VALVE

10 Specification Performance Curve (Measured at $v = 41 \text{ mm}^2/\text{s}$ and $t = 50^\circ\text{C}$)

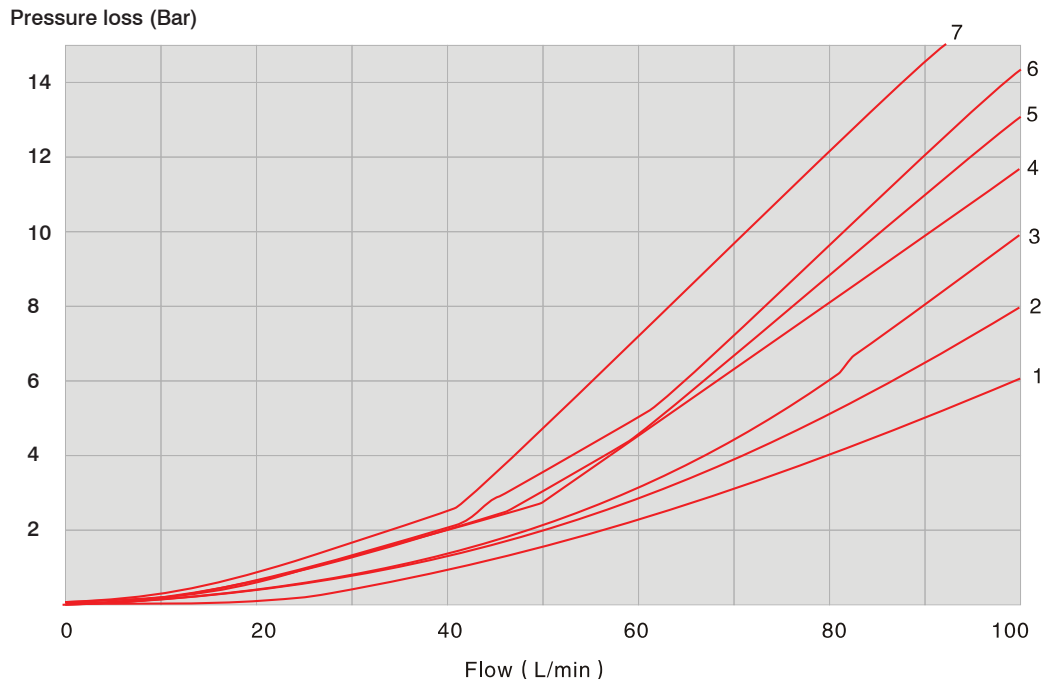

Function code	Direction			
	P→A	P→B	A→T	B→T
288 288L	2	2	-	-
283 282 282L	2	2	3	3
302 307	2	2	4	4
305	2	3	3	5
306	3	3	4	6
303	1	1	4	5
3010 3012	2	2	3	5
309	1	1	5	1
3025	3	2	5	3
3029	2	4	3	-

7. Spool symbol "3029" in the shifting position A → B
 4. Spool symbol 306 in the position P → T

ELECTRICAL OPERATED DIRECTIONAL CONTROL VALVE

10 Specification Working Limits (The working limits for directional valves have determined by using solenoids at their operating temperature, 10% under voltage and with no pre-loading of the tank)

With regard to the four-way valve, the normal flow data as shown is get from the regular use of two directions of the flow (e.g.P to A, and simultaneous return flow from B to T). See tables. If only one flow direction is needed, for example: When a four port valve which is closed up port A or port B, used as a three-way valve, the Maximum flow may be very small in the serious condition.

Working pressure (Bar) DC solenoid operation

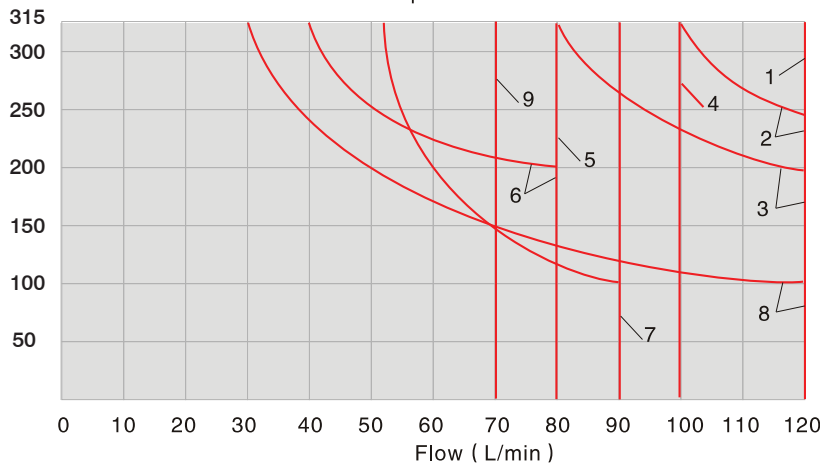

Curve	Symbol
1	283 2N3 2D3
	282 2N2 2D2
	282L 309
2	302
3	2N8 2D8
	3010 3012 304
4	303
5	3029
6	306
7	305 3025
	388 288L
8	307
9	303
1)	Return circuit (Independent of area ratio)

Working pressure (Bar) AC solenoid operation

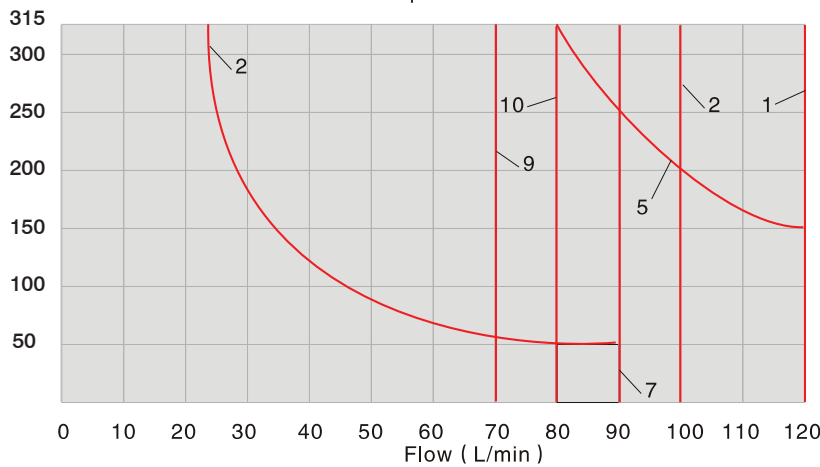

110V,50Hz; 120V,60Hz; 220V,50Hz; 240V,60Hz;	
Curve	Symbol
1	283 2N3 2D3
	282 2N2 2D2
	282L
2	302 3010
	3012
3	309
	288 288L
4	288 288L
	288 2D8 304
5	306
6	305 3025
	307
7	303
8	303
9	303
10	3029

Working pressure (Bar) AC solenoid operation

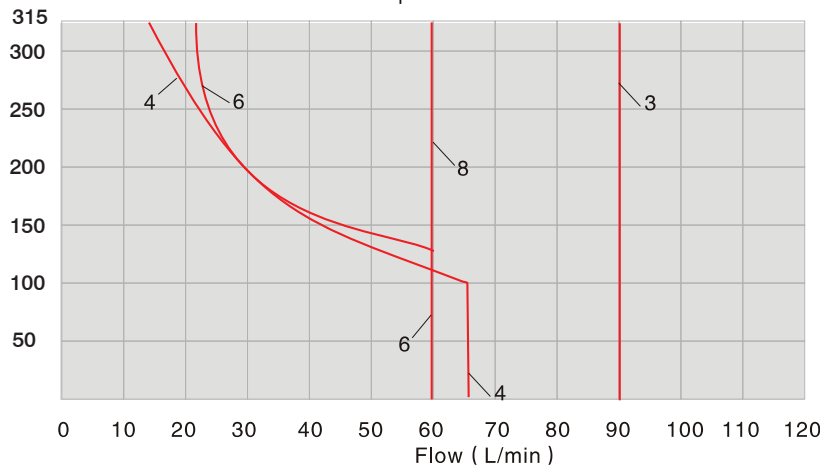

ELECTRICAL OPERATED DIRECTIONAL CONTROL VALVE

External Dimensions (6 Direct Current Plug Type)

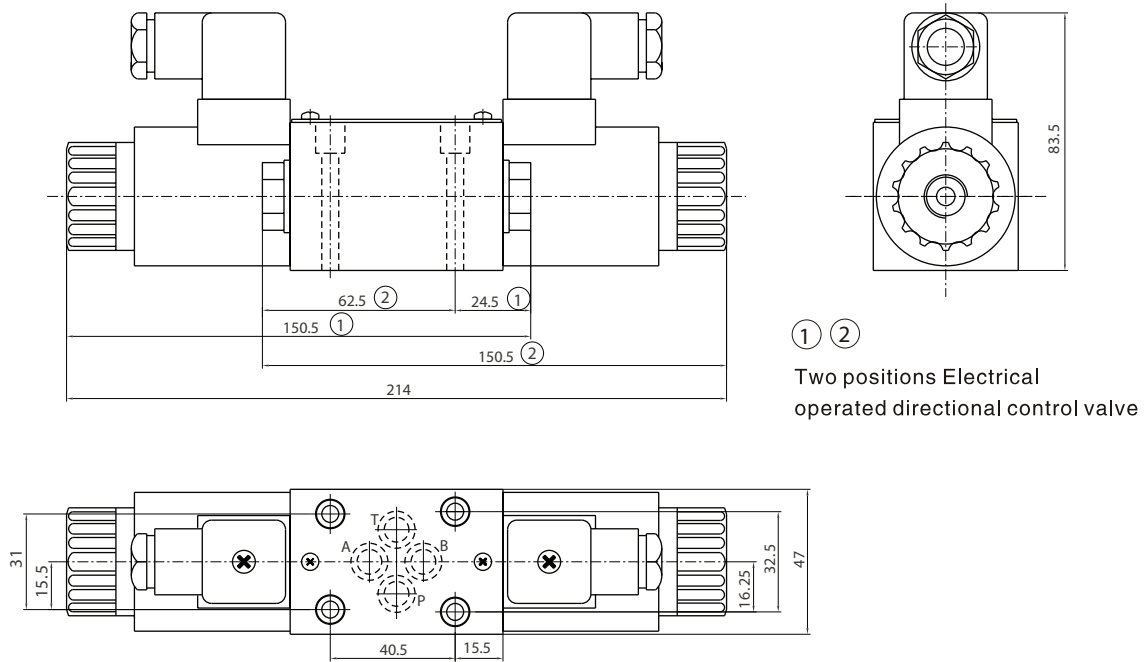

External Dimensions (6 Direct Current Wire Box Type)

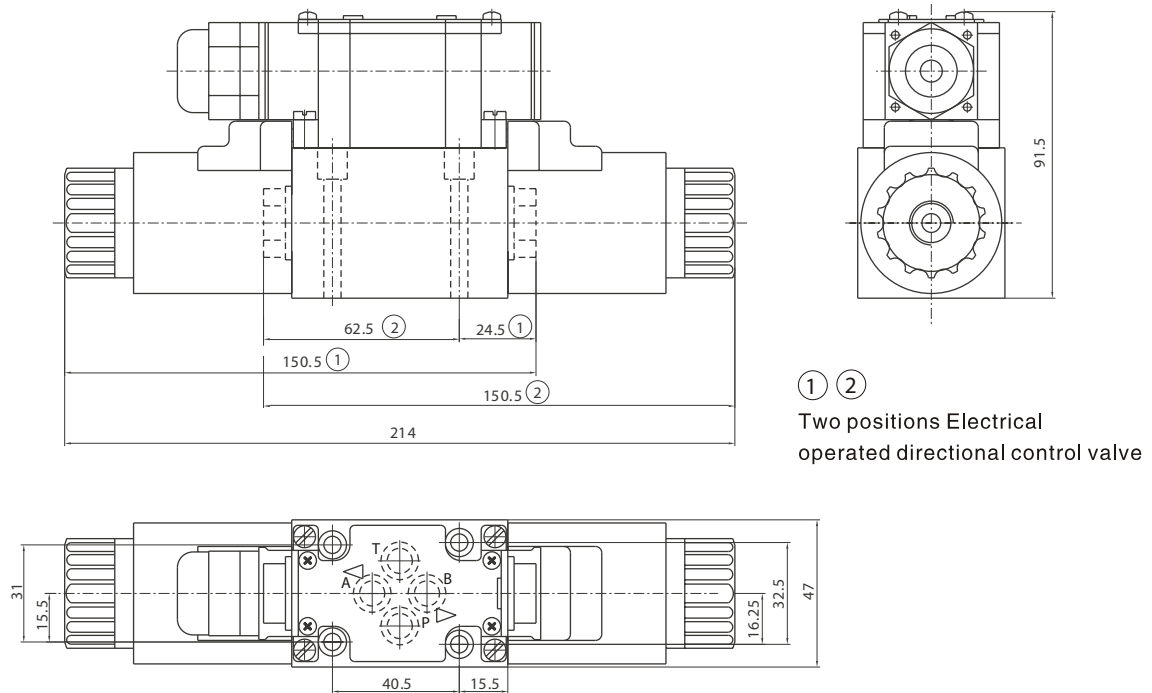

ELECTRICAL OPERATED DIRECTIONAL CONTROL VALVE

External Dimensions (6 Direct Current Plug Type)

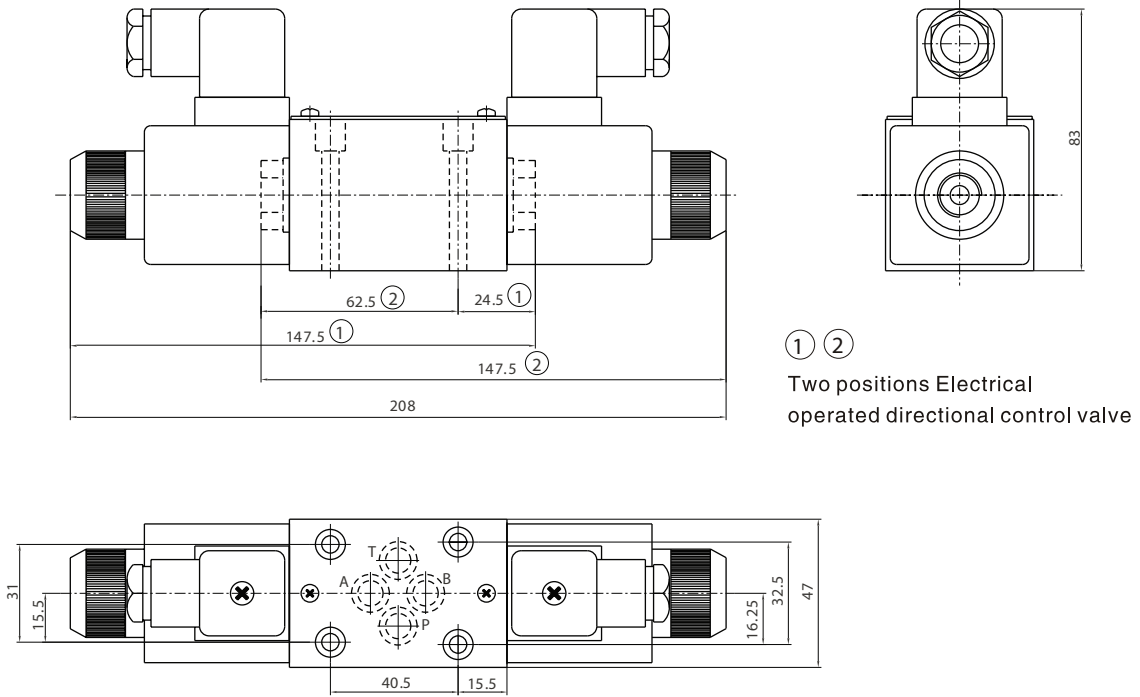

External Dimensions (6 Alternating Current Wire Box Type)

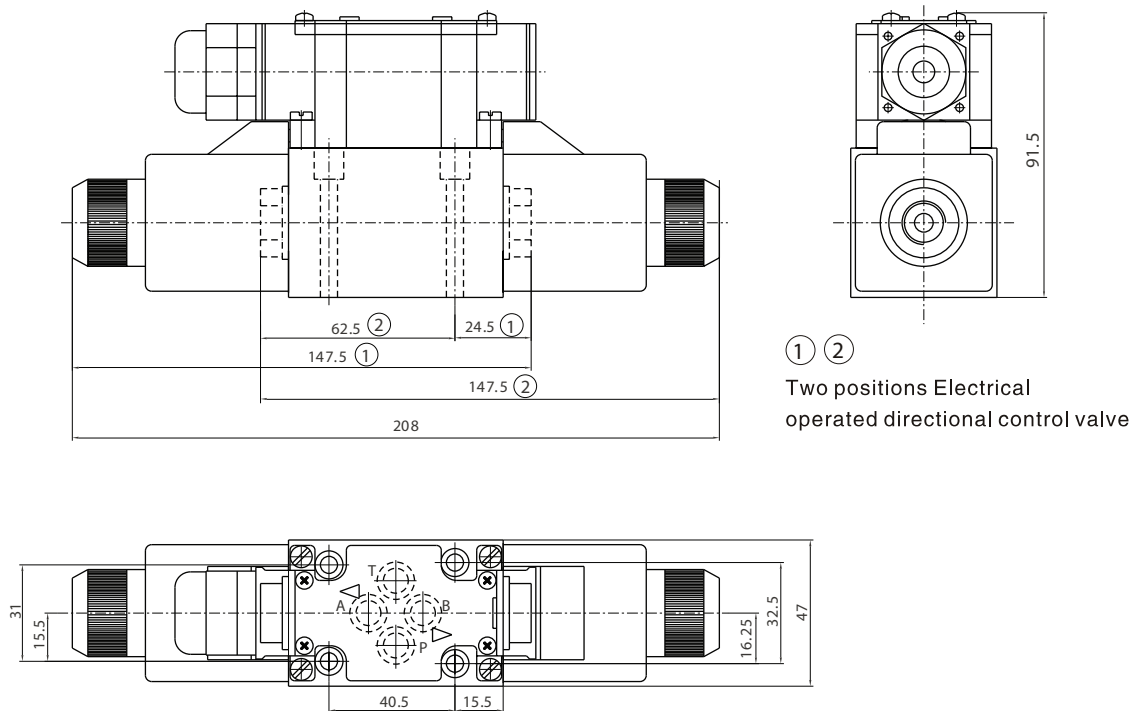

ELECTRICAL OPERATED DIRECTIONAL CONTROL VALVE

6 Size of Subplate Oil Port

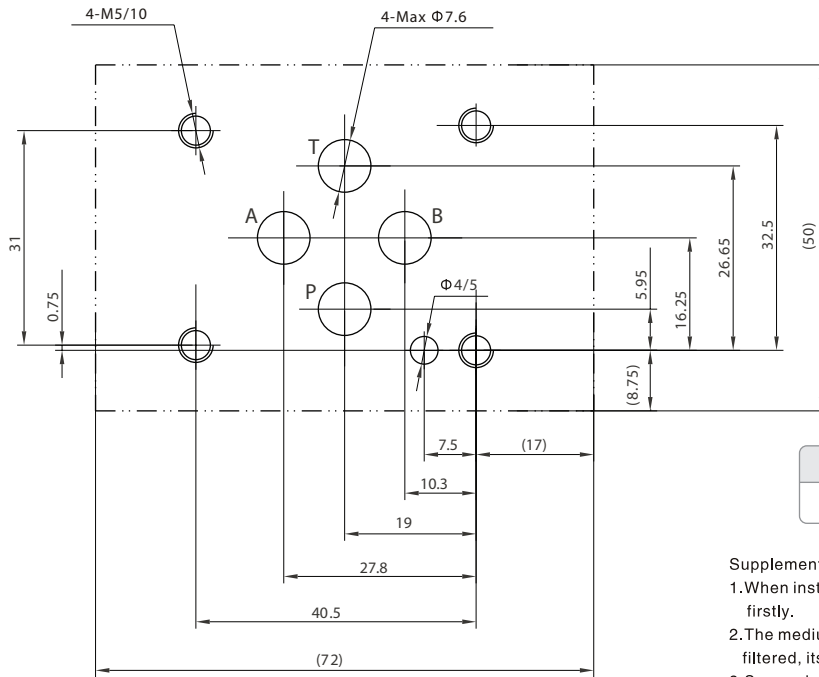

Mounting screw	Amount	Tighten torque
M5x45-10.9	4	9Nm

Supplementary explanation

1. When installing the product, considering horizontal position firstly.
2. The medium used in the hydraulic system must be filtered, its accuracy at least 20 μm.
3. Screw should be according to the parameters in catalogue.
4. The surface, connecting with the valve, should be Ra0.8 roughness, and 0.01/100mm flatness.

External Dimensions (10 Direct Current Plug Type)

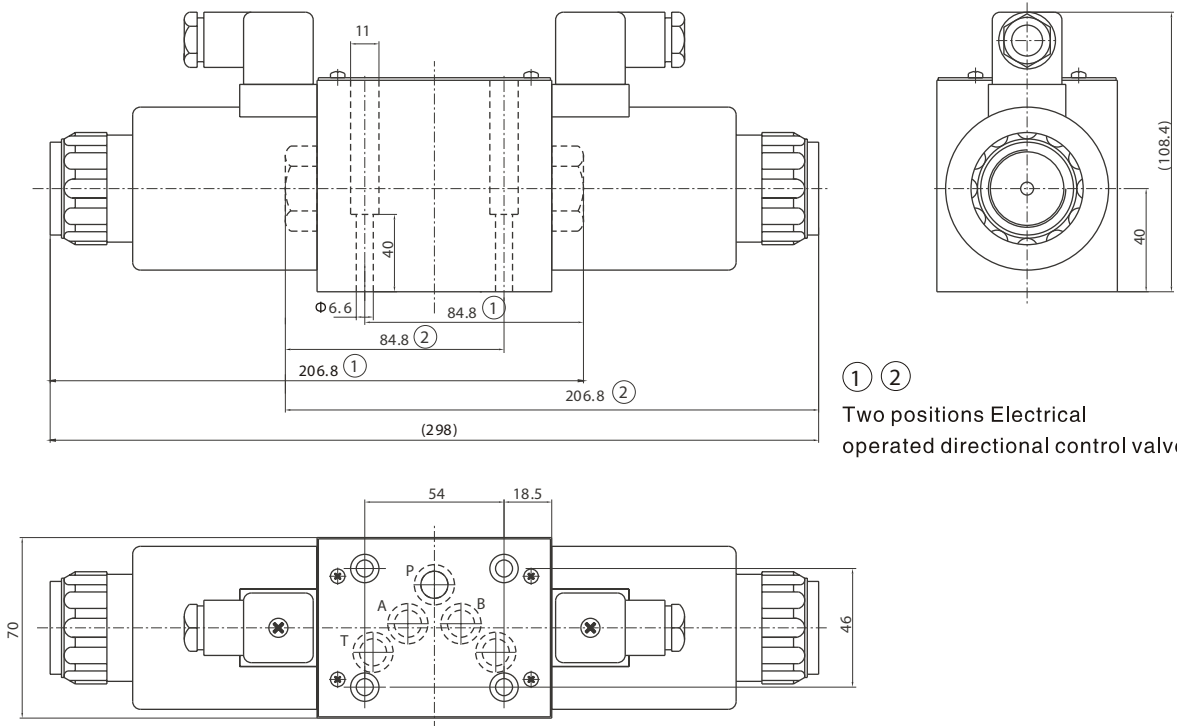

① ②

Two positions Electrical operated directional control valve

ELECTRICAL OPERATED DIRECTIONAL CONTROL VALVE

External Dimensions (10 Alternating Current Plug Type)

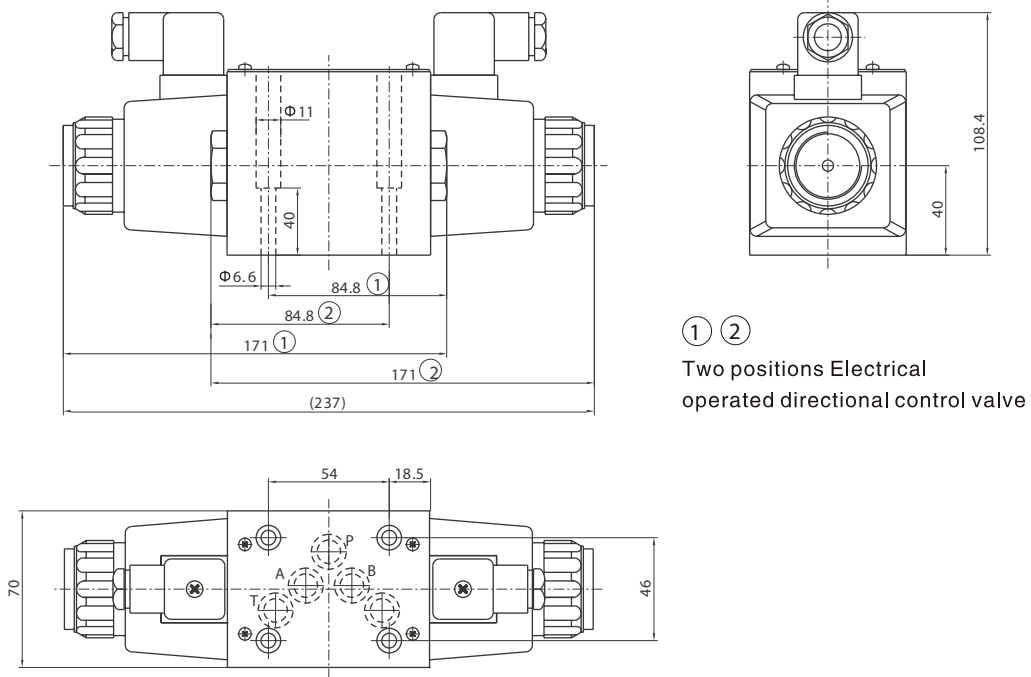

① ②
Two positions Electrical operated directional control valve

10 Size Of Subplate Oil Port

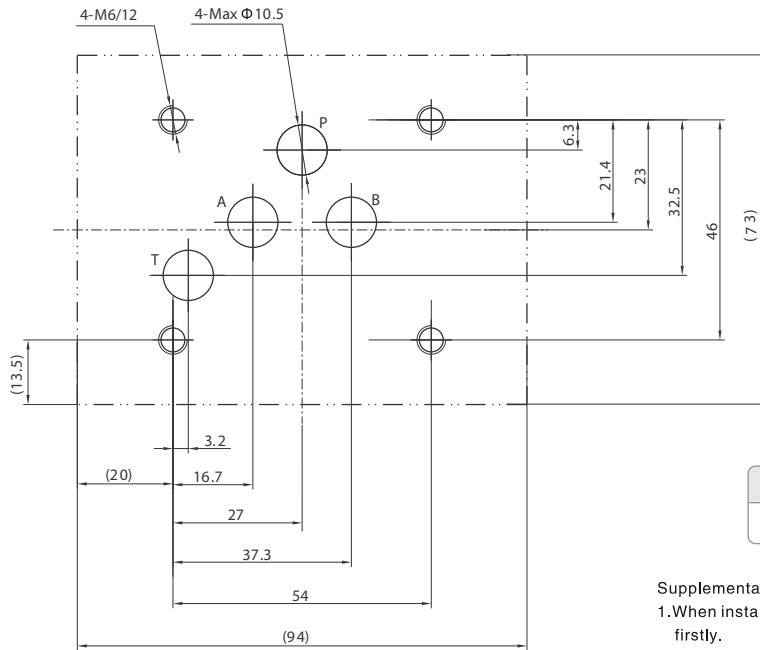

Mounting screw	Amount	Tighten torque
M6X50-10.9	4	15Nm

- Supplementary explanation
1. When installing the product, considering horizontal position firstly.
 2. The medium used in the hydraulic system must be filtered, its accuracy is at least 20 μ m.
 3. Screw should be according to the parameters in catalogue.
 4. The surface, connecting with the valve, should be Ra0.8 roughness, and 0.01/100mm flatness.